

## Glass Product Datasheet - WSL F28

WSL F-glass is range of fire resistant insulating glasses, for both integrity & insulation as defined under BS476 Part 22 and EN1364. These glasses compliment our high performance framing systems and allow us to provide a complete & guaranteed glazing solution.

In the event of a fire each makeup of F-glass provides a barrier against the passage of flame and radiant heat through the glass. This safety specification is commonly used to protect building evacuation routes, the vulnerable areas of adjacent buildings, or where the prevention of fire spread caused by radiant heat is of prime importance.

The protection is achieved through the unique makeup of the glass unit, utilising a central layer of clear UV stable heat reactive gel, contained by two layers of clear toughened glass.

- Competively priced
- Comprehensive test data
- Multiple framing options
- High optical quality
- High light transmission
- Suitable for pressure plate glazing
- UV Stable interlayer
- Unlimited options for external pane
- Class A impact safety
- Large sizes

### WSL F28-makeup (colours shown for clarity)

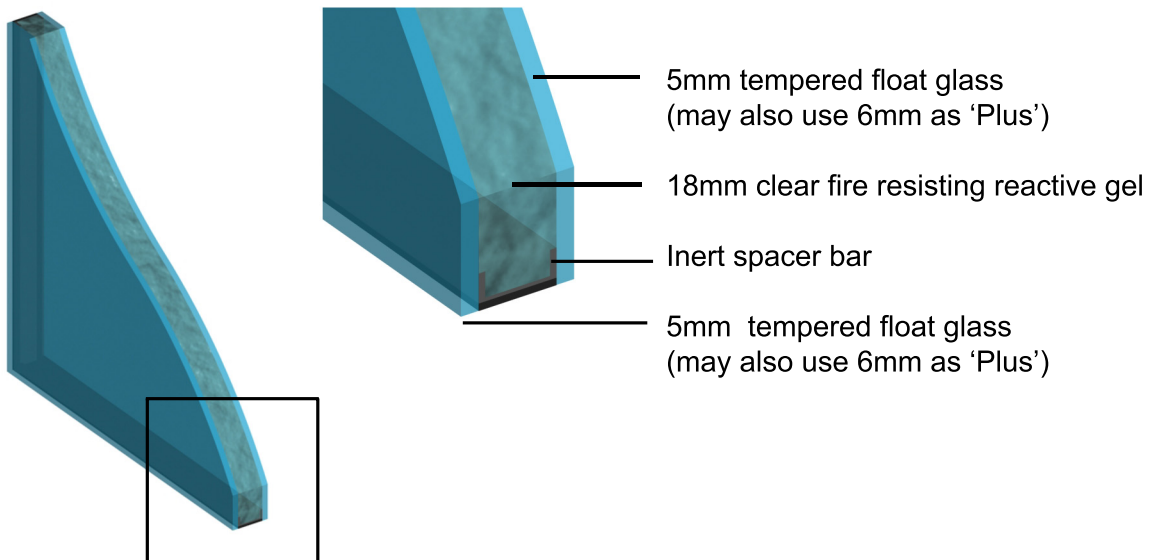

### WSL F28-ISO makeup (colours shown for clarity)

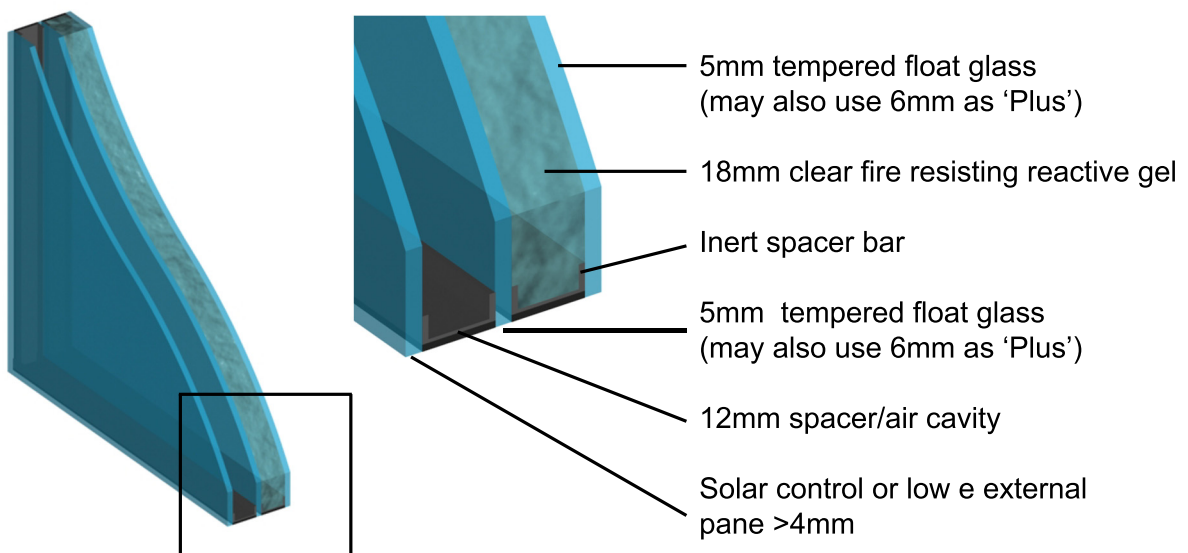

## Glass Product Datasheet - WSL F28

	WSL F28	WSL F28 Plus	WSL F28 - ISO	WSL F28 Plus - ISO
Overall thickness	28mm	30mm	>44mm	>46mm
Fire rating	60/60	60/60	60/60	60/60
Unit makeup	5 / 18 / 5	6 / 18 / 6	5 / 18 / 5 / 12 / >4	6 / 18 / 6 / 12 / >4
Approx weight	46 kg/m <sup>2</sup>	51 kg/m <sup>2</sup>	>56 kg/m <sup>2</sup>	>61 kg/m <sup>2</sup>
DB reduction	44 DB	44 DB	44 DB	44 DB
Light Transmission	86%	86%	73%	73%
UV Stable	Yes - EN12543	Yes - EN12543	Yes - EN12543	Yes - EN12543
Options for external pane	n/a	n/a	4mm minimum	4mm minimum
U-Value	5.6 w/m <sup>2</sup> K	5.6 w/m <sup>2</sup> K	1.4 w/m <sup>2</sup> K	1.4 w/m <sup>2</sup> K
Class A safety	BS6206 - EN12600	BS6206 - EN12600	BS6206 - EN12600	BS6206 - EN12600
Stable temperature range	-20DegC / +50DegC	-20DegC / +50DegC	-20DegC / +50DegC	-20DegC / +50DegC
Minimum production size	100mmW x 300mmH	100mmW x 300mmH	100mmW x 300mmH	100mmW x 300mmH
Quality ratio for toughening	1:10	1:10	1:10	1:10

### WSL F28 permissible dimensions

Type:	Pane Orientation:	Maximum Pane Height	Maximum Pane Width	Maximum Pane Area
WSL F28 (inc ISO)	Portrait	2600mm	1500mm	3.90m <sup>2</sup>
WSL F28 (inc ISO)	Landscape	-	1500mm	3.90m <sup>2</sup>
WSL F28 plus (inc ISO)	Portrait	3585mm	1745mm	5.01m <sup>2</sup>
WSL F28 plus (inc ISO)	Landscape	-	2400mm	4.01m <sup>2</sup>

Note: - WSL F32 may also be used for 60 minute specifications to a larger dimension. Please refer to separate datasheet

#### Directions:

Plot your required glass size on the chart below. Current test data allows for any pane size within the red & blue areas.

If the pane size falls completely within the blue area then either WSL F28 or WSL F28 Plus may be used.

If the pane size falls partly within the red area then only the WSL F28 Plus can be used. This requirement is due to maintaining optical quality only and not fire test limitations.

